



Maxim > Design Support > Technical Documents > Reference Designs > Power-Supply Circuits > APP 5449

Keywords: FPGA, Xilinx, ARM, CPU, SOC, processor, micro, microcontroller, Cortex, multicore, power, power module, Zynq, Zedboard, reference design, point of load regulator, power supply, POL, extensible processing platform, EPP

REFERENCE DESIGN 5449 INCLUDES: ✓Tested Circuit ✓Schematic ✓BOM

Powering the Zynq Evaluation and Development Board (ZedBoard)

By: Takahiro Hayashi

Murali Malla

Aug 21, 2012

Abstract: This reference design explains how to power the Xilinx Zynq Extensible Processing Platform (EPP) and peripheral ICs using Maxim's power-supply solutions.

This fully tested reference design provides a complete solution for powering the Xilinx® Zynq® Extensible Processing Platform (EPP). The board was developed by Avnet and Digilent in close collaboration with Xilinx and Maxim. The Zynq device requires nine unique power supply rails (**Table 1**).

Table 1. Power Rail Descriptions				
Symbol	Description	Output Voltage	Current	Maxim Solution
V _{CCODDR}	Processing system DDR I/O supply voltage	1.5V	1.5A	MAX15021
V _{CCINT}	Programmable logic (PL) internal supply voltage	1.0V	1.3A	
Adjustable V _{CCO}	Power supply for I/O banks	3.3V/2.5V/1.8V	2A	MAX15021
V _{CCO}	Power supply for I/O banks	3.3V	3A	
V _{CCAUX}	PL auxiliary supply voltage	1.8V	0.8A	MAX15053
V _{CCADC}	XADC supply	1.8V	150mA	MAX1983
V _{REFP}	External reference voltage for XADC	1.25V	5mA	MAX6037A
V _{TT}	DDR3 termination supply	0.75V	1A	MAX1510
V _{CC5V0}	5V power supply from 12V	5V	6A	MAX8686

This reference design provides the required nine power rails to the Zynq device, DDR3 memory, FMC connector, and other devices on the board. This is done using two MAX15021 dual-output monolithic synchronous pulse-width modulation (PWM) step-down regulators, one MAX15053 high-efficiency synchronous step-down regulator, the MAX1983 low-dropout linear regulator, the MAX6037A reference voltage, the MAX1510 low-voltage DDR linear regulator, and the MAX8686 monolithic synchronous step-down regulator. Customers who can use 5V as V_{IN} do not need the MAX8686 in their designs. All devices can be sequenced at power-up, as indicated in **Figure 1**.

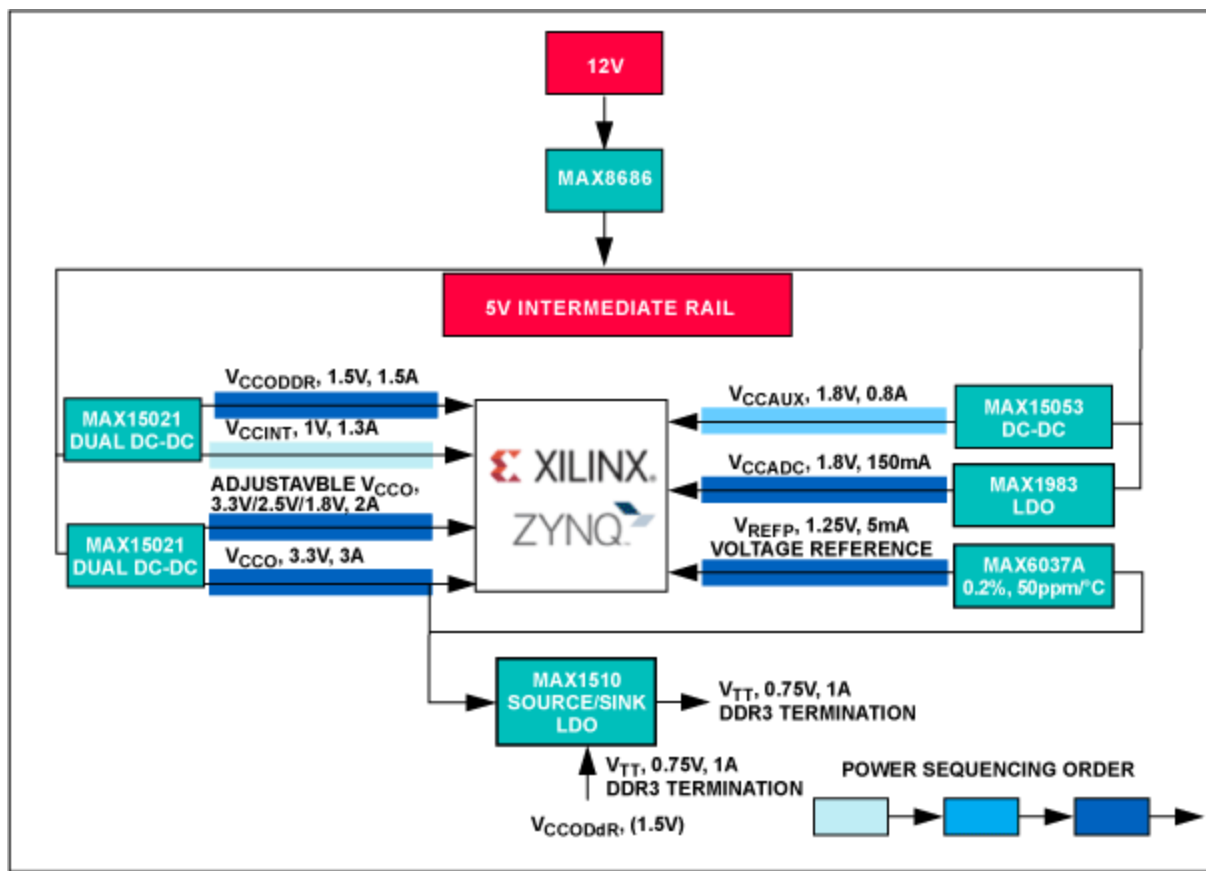
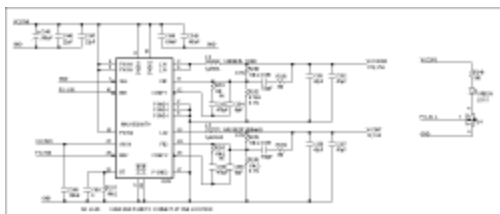

Figure 1. Block diagram of the Zynq power architecture.

These point-of-load (POL) regulators were chosen for this design due to their accuracy, small size, and ease of use. Avnet considered solutions from a number of competitive power IC suppliers and chose Maxim for its ideal fit in technical capability, ease of use, and solution cost to meet Zynq EPP power requirements. The MAX15021 dual monolithic synchronous step-down converter is capable of providing up to 4A and 2A from a 5mm x 5mm package. The MAX15053 monolithic synchronous step-down converter can provide up to 2A with very low on-resistance internal MOSFETs. The MAX1983 low-dropout linear regulator can provide up to 300mA, the MAX1510 low-voltage DDR linear regulator, the MAX6037A 0.2% high-accuracy voltage reference and the MAX8686 monolithic synchronous step-down converter are capable of providing up to 25A.

Detailed schematics for each POL are shown below in **Figures 2** through **8**, and the complete bill of materials (BOM) is included at the end of this document. This evaluation board can be purchased from Avnet. More information is available in a [video](#) from Maxim, Xilinx, and Avnet.



[More detailed image \(PDF, 249kB\)](#)

Figure 2. The MAX15021 is used to supply 1.5V/1.5A for V_{CCODDR} and 1V/1.3A for V_{CCINT} .

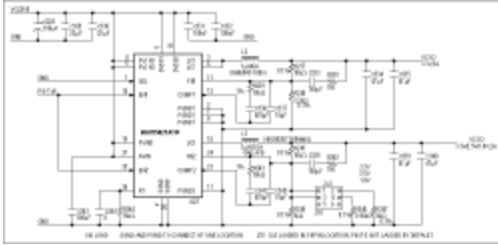

[More detailed image \(PDF, 264kB\)](#)

Figure 3. The MAX15021 is used to supply fixed 3.3V/3A for V_{CCO} and 3.3V, 2.5V, 1.8V/2A for adjustable V_{CCO} .

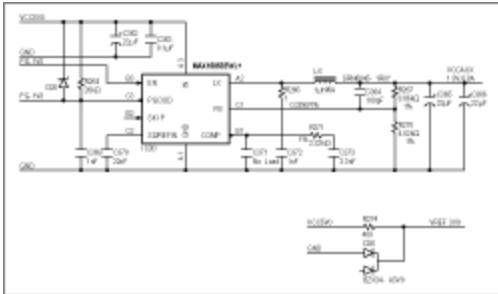

[More detailed image \(PDF, 211kB\)](#)

Figure 4. The MAX15053 is used to supply 1.8V/0.8A for V_{CCAUX} .

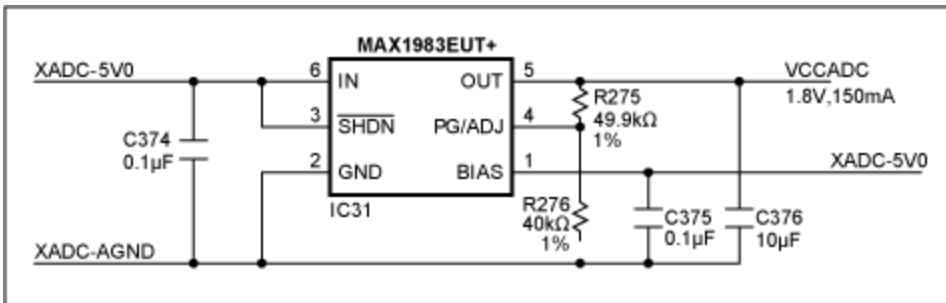

Figure 5. The MAX1983 is used to supply 1.8V/150mA for V_{CCADC} .

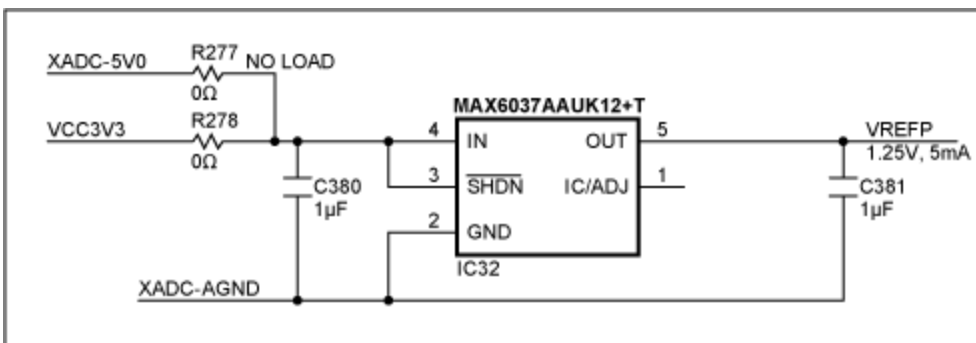

Figure 6. The MAX6037A is used to supply 1.25V/5mA for V_{REFP} .

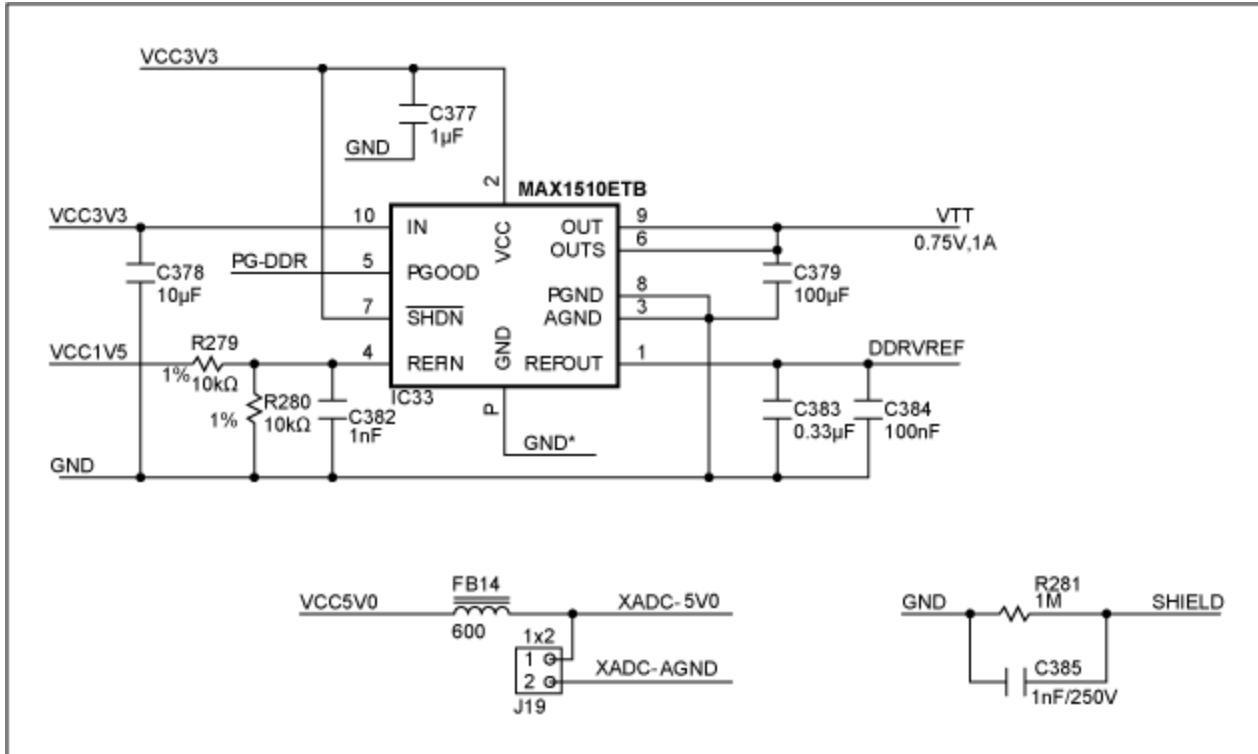
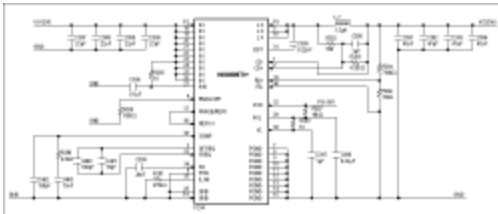

Figure 7. The MAX1510 is used to supply 0.75V/±1A for DDR V_{TT}.



More detailed image (PDF, 257kB)
 Figure 8. The MAX8686 is used to supply 5V.

Table 2. Bill of Materials (BOM)

Designator	Value	Comment	Footprint	Description	Quantity	Manufacturer
BTN6, BTN7		SW-P8008 with RED CAP	SW-P8008	Push Button Switch, SPST, Thru Hole	2	
BTN8, BTN9, BTNC, BTND, BTNL, BTNR, BTNU		SW-P8008	SW-P8008	Push Button Switch, SPST, Thru Hole	7	
C1, C2, C4, C5, C7, C19, C21, C36, C37, C38, C43, C51, C52, C53, C57, C59, C61, C62, C63, C65, C66, C68, C69, C70, C71, C72, C79, C80, C81, C84, C85, C86, C90, C91, C93, C94, C95, C96, C98, C106, C252, C253, C254, C257, C260, C264, C266, C267, C270, C271, C272, C273, C363, C374, C375	0.1µF	CAPACITOR	CAP0402	Generic Capacitor	55	
C108, C109,						

C110,
C111,
C112,
C113,
C114,
C122,
C123,
C124,
C125,
C126,
C142,
C143,
C144,
C145,
C146,
C155,
C156,
C161,
C162,
C167,
C168,
C169,
C170,
C171,
C181,
C182,
C183,
C189,
C190,
C191,
C192,
C193,
C234,
C235,
C236,
C241,
C242,
C243,
C278,
C279,
C280,
C281,
C282,
C283,
C284,
C285,
C286,
C287,
C288,
C289,
C290,
C291,

47nF

CAPACITOR

CAP0402

Generic Capacitor

72

C292,
C293,
C294,
C295,
C296,
C297,
C298,
C299,
C300,
C301,
C302,
C303,
C304,
C305,
C306,
C307,
C308,
C309

C12, C318,
C319,
C320,
C321,
C322,
C323,
C331,
C332,
C343,
C348,
C349,
C360,
C384

100nF

CAPACITOR

CAP0402

Generic Capacitor

14

C127,
C137,
C138,
C147,
C154,
C160,
C172,
C180,
C194,
C233,
C244,
C310,
C311,
C313,
C314

470nF

CAPACITOR

CAP0402

Generic Capacitor

15

C131,
C132,
C133,
C151,

C152, C158, C176, C177, C198, C230, C247, C248, C379	100µF	CAPACITOR	CAP1210	Generic Capacitor	13
C15, C16, C23, C24	100nF	No Load	CAP0402	Generic Capacitor	4
C199, C200, C201, C202, C203, C209, C210, C211, C212, C213, C214, C215	47nF	Murata GRM Series	CAP0402	Generic Capacitor	12
C204, C205, C206, C207, C208	10nF	Murata GRM Series	CAP0402	Generic Capacitor	5
C216, C227, C228, C229	100µF	Murata GRM Series	CAP1210	Generic Capacitor	4
C217, C218, C219, C222, C223, C224, C225, C226	4.7µF	Murata GRM Series	CAP0603	Generic Capacitor	8
C220	470nF	Murata GRM Series	CAP0402	Generic Capacitor	1
C221	0.47µF	Murata GRM Series	CAP0402	Generic Capacitor	1
C25, C26, C27, C28, C39, C44, C54, C73, C74, C75,					

C78, C255, C258, C261, C265, C324, C325, C377, C386, C397	1µF	CAPACITOR	CAP0402	Generic Capacitor	20
---	-----	-----------	---------	-------------------	----

C29, C31, C32, C33, C34, C35, C41, C42, C46, C47, C48, C49, C50, C56, C97, C101, C103, C104, C105, C107, C115, C116, C117, C118, C119, C120, C121, C139, C140, C141, C157, C163, C164, C165, C166, C184, C185, C186, C187, C188, C237, C238, C239, C240, C249, C250, C256, C259, C262, C263,	10nF	CAPACITOR	CAP0402	Generic Capacitor	58
---	------	-----------	---------	-------------------	----

C268, C269, C274, C275, C276, C277, C316, C317					
C3, C6	220μF	No Load	CPOL3528	Generic Polarized Capacitor	2
C30	NL	CAPACITOR	CAP0603	Generic Capacitor	1
C328, C345	100μF	CPOL	CAP1210	Generic Polarized Capacitor	2
C329, C330, C346, C347	22μF	CAPACITOR	CAP0805	Generic Capacitor	4
C333, C338, C350, C355	750pF	CAPACITOR	CAP0402	Generic Capacitor	4
C334, C335, C339, C340, C351, C352, C356, C357	47μF	CAPACITOR	CAP1210	Generic Capacitor	8
C336, C341, C353, C358	470pF	CAPACITOR	CAP0402	Generic Capacitor	4
C337, C342, C354, C359	10pF	CAPACITOR	CAP0402	Generic Capacitor	4
C344, C361	0	No Load	CAP0402	Generic Capacitor	2
C362, C365, C366	22μF	CPOL	CAP1210	Generic Polarized Capacitor	3
C364	100pF	CAPACITOR	CAP0402	Generic Capacitor	1
C368	220nF	15%, 10V	CAP0402	Generic Capacitor	1

C370	22nF	CAPACITOR	CAP0402	Generic Capacitor	1	
C371	No Load	CAPACITOR	CAP0402	Generic Capacitor	1	
C373	3.3nF	CAPACITOR	CAP0402	Generic Capacitor	1	
C380, C381	1 μ F	CAPACITOR	CAP0805	Generic Capacitor	2	
C383	0.33 μ F	CAPACITOR	CAP0402	Generic Capacitor	1	
C385	1nF/250V	CAPACITOR	CAP0805	Generic Capacitor	1	
C387, C388, C389, C390	22 μ F	25V	CAP1210	Generic Capacitor	4	
C391, C392, C393, C394	47 μ F	GRM32ER71A476KE15	CAP1210	Generic Capacitor	4	Murata
C395, C398	0.22 μ F	CAPACITOR	CAP0402	Generic Capacitor	2	
C396	0.1 μ F	25V	CAP0402	Generic Capacitor	1	
C399	20nF	CAPACITOR	CAP0402	Generic Capacitor	1	
C40, C45, C55, C58, C251	10 μ F	CAPACITOR	CAP0603	Generic Capacitor	5	
C400	330pF	CAPACITOR	CAP0402	Generic Capacitor	1	
C401	15pF	CAPACITOR	CAP0402	Generic Capacitor	1	
C402	150pF	CAPACITOR	CAP0402	Generic Capacitor	1	
C403	15nF	CAPACITOR	CAP0402	Generic Capacitor	1	
C64, C67, C128, C129, C130, C134, C135, C136, C148, C149, C150, C153, C159, C173, C174, C175,	4.7 μ F	CAPACITOR	CAP0603	Generic Capacitor	27	

C178, C179, C195, C196, C197, C231, C232, C245, C246, C312, C315							
C76, C77	39pF	5%		CAP0402	Generic Capacitor	2	
C8, C10, C11, C13, C14, C17, C18, C20, C22, C60, C376, C378	10µF	CAPACITOR		CAP0805	Generic Capacitor	12	
C82, C83	2.2µF	CAPACITOR		CAP0603	Generic Capacitor	2	
C87, C92, C326, C327	2.2µF	CAPACITOR		CAP0402	Generic Capacitor	4	
C88	4.7µF	10V		CAP0603	Generic Capacitor	1	
C89	120µF	10V		CAP1210	Generic Polarized Capacitor	1	
C9	9.1pF	CAPACITOR		CAP0402	Generic Capacitor	1	
C99, C100, C102, C367, C369, C372, C382	1nF	CAPACITOR		CAP0402	Generic Capacitor	7	
D1, D2, D3, D4, D5, D6, D7, D8, D9, D10, D12, D13, D14, D17, D19, D20, D21		SESD0802Q4UG-0020-090	SESD0802Q4UG	Quad Diode Array for ESD protection		17	TE Connectivity
D11		BAS16XV2T1-D	SOD-523	Surface Mount ESD Protection Diode		1	On Semiconductor
				Surface Mount ESD			TE

D15		PESD0402-140	D0603	Protection Diode	1	Connectivity
D16, D18, D22, D23, D24, D25		RB751S40	SOD-523	Schotkey Diode NOT GENERIC	6	
D26		BZX34-A3V0	SOT23	Dual Common Cathode Surface Mount Rectifier	1	Vishay
DISP1		UG-2832HSWEG04	UG- 2832HSWEG04	OLED, 128x32 monochrome, Passive Matrix Module	1	Wisechip
F1, F2, F3, F4		Foot	Foot#6	Mechanical Foot for #6 Screw or Rubber Pad	4	
F5	5A	0603SFF500F/32-2	RES0603	Generic Resistor	1	
FB1, FB2, FB3, FB4, FB5, FB8, FB9, FB11, FB12, FB13, FB14	600	MPZ2012S601A	FB0805	Generic Ferrite Bead	11	
FB10	No Load	MPZ2012S601A	FB0805	Generic Ferrite Bead	1	
FB6, FB7	220	SMB-201209-F2-221P	FB0805	Generic Ferrite Bead	2	
IC1		74LCX125BQX	DQFN14	Low Voltage Quad Tri-State Buffer with 5V Tolerant I/O	1	Fairchild
IC10		TUSB1210BRHB	QFN32 - C	ULPI Hi-Speed USB OTG transceiver	1	Texas Instruments
IC11		CY7C64225-28PVXC	SSOP28	Full-Speed USB to UART Controller	1	Cypress
IC12	26MHz	767-26-31	HC5	3.3V HCMOS Oscillator	1	Fox Electronics
IC13		TXS0102DQE	DQE8	2-Bit Bidirectional Voltage-Level Translator	1	Texas Instruments
IC14	No Load	S25FL256SAGNFI00	MLP8	Serial Flash Memory, 16Mbit, Low Voltage, 50MHz SPI Bus Interface	1	Spansion
				Serial Flash		

IC15		S25FL256SAGMFI00	SOIC16-WIDE	Memory, 16Mbit, Low Voltage, 50MHz SPI Bus Interface	1	Spansion
IC16		XC7Z020CLG484	CSG484	Zynq 7000 FPGA 20 Die, in a CSG 484 Package	1	Xilinx
IC17	100MHz	767-100-136	HC5	3.3V HCMOS Oscillator	1	Fox Electronics
IC18	33.33MHz	767-33.333333-12	HC5	3.3V HCMOS Oscillator	1	Fox Electronics
IC19		74LCX126BQX	DQFN14	Low voltage Quad Tri-State Buffer with 5V tolerant I/O	1	Fairchild
IC2		ADG719BRTZ	SOT23-6	2:1 Mux/SPDT Switch	1	Analog Devices
IC20		NC7WZ07P6X	SOT-363	TinyLogic UHS Dual Buffer	1	Fairchild
IC21		NC7SZ125M5X	SOT23-5	TinyLogic UHS Buffer with Tri-State Output	1	Fairchild
IC22	12MHz	767-12-69	HC5	3.3V HCMOS Oscillator	1	Fox Electronics
IC23		SMT1	SMT1	USB to JTAG circuit	1	Digilent
IC24		93LC56BT	SOT23-6	2K Microwire Compatible Serial EEPROM	1	Microchip
IC25, IC26		MT41J128M16HA- 15E:D	FBGA96	DDR3 SDRAM 4Gb x4, x8, x16	2	Micron
IC27, IC28		MAX15021ATI+	QFN28-5X5	Dual, 4A/2A, 4MHz, Step-Down DC-DC Regulator with Tracking/Sequencing Capability	2	Maxim
IC29		LM339M	SOIC14N	Quad Low Power, Precision Comparator	1	Texas Instruments
IC3		ADAU1761BCPZ	QFN32	SigmaDSP Stereo, Low Power, 96kHz, 24-Bit Audio Codec with Integrated PLL	1	Analog Devices
				High-Efficiency, 2A, Current-Mode		

IC30		MAX15053EWL+	WLP9	Synchronous, Step-Down Switching Regulator	1	Maxim
IC31		MAX1983EUT+	SOT23-6	Low-Voltage, Low-Dropout Linear Regulators with External Bias Supply	1	Maxim
IC32		MAX6037AAUK12+T	SOT23-5L	Low-Power, Fixed and Adjustable Reference with Shutdown	1	Maxim
IC33		MAX1510ETB	DFN10	Low-Voltage, DDR Linear Regulators	1	Maxim
IC34		MAX8686ETL+	TQFN40	Single/Multiphase, Step-Down DC-DC Converter Delivers Up to 25A Per Phase	1	Maxim
IC4		ADP150ACBZ-3.3	WLCSP4	Ultra-Low Noise, 150mA CMOS Linear Regulator	1	Analog Devices
IC5	12MHz	767-12-68	HC5	3.3V HCMOS Oscillator	1	Fox Electronics
IC6	225MHz	ADV7511KSTZ	LQFP100	Low-Power HDMI Transmitter with Audio Return Channel	1	Analog Devices
IC7		88E1518-XX-NNB2C000	QFN48	High Integrated 10/100/1000 Ultra Gigabit Ethernet Transceiver	1	Marvell
IC8		TXS02612RTWR	QFN24	SDIO Port Expander with Voltage-Level Translation	1	Texas Instruments
IC9		TPS2051BDBV	DBV-5	Current-Limited, Power-Distribution Switch	1	Texas Instruments
J1		ASP-134603-01	ASP-134603-01	FMC SEARAY mezzanine connector, 160 pins	1	Samtec
J10		1-1734530-3	TE1734530	DB15F-HD 15 Pin Edge Connector	1	TE Connectivity
				Single Port		

J11		1840808-7	TE1840808	10/100/1000Base-TX RJ-45 Connector with Magnetics	1	TE Connectivity
J12		2041021-1	TE2041021	DM1 Series SD Memory Card Connector	1	TE Connectivity
J13, J14, J17		1981584-1	TE 1981584	USB Micro AB connector	3	TE Connectivity
J15		HDR-2x7-2mm	HDR-2X7 -2mm	Header 2mm 2x7	1	
J16, J19		No Load	HDR-1x2	Header 100mil 1x2	2	
J18		Special, load HDR-2x2	HDR-2x3	Header 100mil 2x3	1	
J2		TST-110-01-G-D	TST-110-01-G-D	Header 100mil 2x10 MTE	1	Samtec
J20		163-054, 2.5x5.5mm, RA	KLD-0202s	Coax power Connector	1	Kingfont Precision Ind.
J21		HDR-1x2	HDR-1x2	Header 100mil 1x2	1	
J3, J4		TP	HDR-1X1	Header 100mil 1x1	2	
J5		BLACK	ST-3000	ST-3000 Series 3.5mm Audio Jack	1	Kycon
J6		GREEN	ST-3000	ST-3000 Series 3.5mm Audio Jack	1	Kycon
J7		PINK	ST-3000	ST-3000 Series 3.5mm Audio Jack	1	Kycon
J8		BLUE	ST-3000	ST-3000 Series 3.5mm Audio Jack	1	Kycon
J9		5-1903015-1	HDMI_1903015	HDMI 1903015, 19 Pin Edge Connector with Shield, (Molex)	1	TE Connectivity
JA1, JB1, JC1, JD1, JE1		PMOD-2x6-S	PMOD-2x6	Pmod System Board Header 2x6, 100mil spaced	5	
JP1, JP2, JP3, JP6, JP12, JP13		JMP-1x2	JPR-1x2	Jumper 100mil 1x2	6	
JP4, JP5		No Load	JPR-1x2	Jumper 100mil 1x2	2	
JP7, JP8, JP9, JP10, JP11		JMP-1x3	JPR-1x3	Jumper 100mil 1x3	5	
L1	1.2nH	CLH1608T-1N2S-S	IND0603	Generic Inductor	1	Taiyo Yuden

L2, L4	1µH/6A	SNR6045-1R0N	CDRH6D38	Generic Inductor	2	
L3, L5	1µH/3.6A	NRS5020T1R0NMGJ	SD5012D	Generic Inductor	2	
L6	1µH/6A	SRN6045-1R0Y	CDRH6D38	Generic Inductor	1	
L7	1.5µH	744314150	CR43	Generic Inductor	1	Würth Electronics
LD0, LD1, LD2, LD3, LD4, LD5, LD6, LD7	RED	LED	D0603	Generic LED	8	
LD10, LD11	YLW	LED	D0603	Generic LED	2	
LD12	BLUE	LED	D0603	Generic LED	1	
LD13	GREEN	LED	D0603	Generic LED	1	
LD9	GRN	LED	D0603	Generic LED	1	
LG1		Zed Board Logo	LOGO_ZED_1.5	Zed Board Logo at 1" wide	1	
LG2		Logo_Digilent-BT	Logo_Digilent-BT_1.0	Digilent Logo	1	
LG3		Logo_ROHS	LOGO_ROHS	ROHS (WEEE) Symbol	1	
LG4		Logo_Chinese ROHS	LOGO_CHINESE-ROHS	Chinese ROHS Symbol	1	
LG5		Logo_Avnet	Logo_Avnet_1.0	Avnet Logo	1	
LG6		Logo_CE	Logo_CE	CE logo	1	
Q1		MBT3904DW1T1	SOT-363	Dual general Purpose Transistors	1	ON Semiconductor
Q2, Q3		NTS2101P	SOT-323 (SC-70)	Single P-Channel Power Mosfet 1.4A, 8V	2	ON Semiconductor
Q4		FDV301N	SOT23	Single Digital FET, N-Channel	1	Fairchild
R1, R38, R43, R47, R48, R56, R57, R58, R60, R61, R62, R63, R64, R65, R66, R67,						

R68, R69, R70, R71, R72, R73, R74, R82, R83, R84, R85, R98, R99, R107, R132, R134, R136, R160, R165, R176, R198, R199, R200, R201, R203, R205, R206, R207, R262, R287	10kΩ	RESISTOR	RES0402	Generic Resistor	46
R100, R101, R177, R178, R179, R180, R182, R183, R184, R264	20kΩ	RESISTOR	RES0402	Generic Resistor	10
R102	27kΩ	RESISTOR	RES0402	Generic Resistor	1
R103, R104	50Ω	1%	RES0402	Generic Resistor	2
R105, R106	1.74kΩ	RESISTOR	RES0402	Generic Resistor	2
R110, R114, R121	4kΩ	RESISTOR	RES0402	Generic Resistor	3
R113, R120, R124	510Ω	RESISTOR	RES0402	Generic Resistor	3
R116	2.43kΩ	1%	RES0402	Generic Resistor	1
R125	887Ω	1%	RES0402	Generic Resistor	1

R129, R130	55Ω	RESISTOR	RES0402	Generic Resistor	2
R131, R141, R142, R143, R189, R190, R196, R197, R260, R261	100kΩ	RESISTOR	RES0402	Generic Resistor	10
R133	4.99kΩ	1%	RES0402	Generic Resistor	1
R137	390kΩ	RESISTOR	RES0402	Generic Resistor	1
R138, R140, R173	499Ω	RESISTOR	RES0402	Generic Resistor	3
R146, R278	0Ω	RESISTOR	RES0805	Generic Resistor	2
R148, R149	24Ω	1%	RES0402	Generic Resistor	2
R157	330Ω	RESISTOR	RES0402	Generic Resistor	1
R159	270Ω	RESISTOR	RES0402	Generic Resistor	1
R170, R181	24Ω	RESISTOR	RES0402	Generic Resistor	2
R171, R172	10kΩ	1%	RES0402	Generic Resistor	2
R174, R175, R236	80Ω	1%	RES0402	Generic Resistor	3
R191, R192, R195, R202	4.99kΩ	RESISTOR	RES0402	Generic Resistor	4
R193	470Ω	RESISTOR	RES0402	Generic Resistor	1
R2, R3, R117, R118, R128, R135, R139, R158,	4.7K	RESISTOR	RES0402	Generic Resistor	11

R161, R211, R212					
R204	12kΩ	RESISTOR	RES0402	Generic Resistor	1
R209, R210	240Ω	1%	RES0402	Generic Resistor	2
R213, R214, R215, R216, R217, R218, R219, R220, R221, R222, R223, R224, R225, R226, R227, R228, R229, R230, R231, R232, R233, R234, R235	40Ω	1%	RES0402	Generic Resistor	23
R237, R241, R249, R253, R279, R280	10kΩ	0.1%	RES0402	Generic Resistor	6
R238, R242, R250, R254	150Ω	RESISTOR	RES0402	Generic Resistor	4
R239, R243, R251, R255	18kΩ	1%	RES0402	Generic Resistor	4
R240	2.2kΩ	0.1%	RES0402	Generic Resistor	1
R244, R257	16kΩ	RESISTOR	RES0402	Generic Resistor	2

R245	5kΩ	0.1%	RES0402	Generic Resistor	1
R246	8.56kΩ	0.1%	RES0402	Generic Resistor	1
R247	4kΩ	0.1%	RES0402	Generic Resistor	1
R252	6.7kΩ	0.1%	RES0402	Generic Resistor	1
R256	15kΩ	0.1%	RES0402	Generic Resistor	1
R258, R272	100kΩ	1%	RES0402	Generic Resistor	2
R259	37.5kΩ	1%	RES0402	Generic Resistor	1
R263	33kΩ	1%	RES0402	Generic Resistor	1
R265, R286	15K	1%	RES0402	Generic Resistor	2
R266	1Ω	0.25W/1%	RES0805	Generic Resistor	1
R267	8.06kΩ	0.1%	RES0402	Generic Resistor	1
R269	9.7kΩ	1%	RES0402	Generic Resistor	1
R270	4.02kΩ	0.1%	RES0402	Generic Resistor	1
R271	2.32kΩ	1%	RES0402	Generic Resistor	1
R273	21.5kΩ	1%	RES0402	Generic Resistor	1
R274	400Ω	RESISTOR	RES0402	Generic Resistor	1
R275	49.9kΩ	0.1%	RES0402	Generic Resistor	1
R276	40kΩ	0.1%	RES0402	Generic Resistor	1
R281	1MΩ	RESISTOR	RES0805	Generic Resistor	1
R283	4.32kΩ	RESISTOR	RES0402	Generic Resistor	1
R284	7.68kΩ	1%	RES0402	Generic Resistor	1
R285, R289	10	RESISTOR	RES0402	Generic Resistor	2
R288	182kΩ	RESISTOR	RES0402	Generic Resistor	1
R290	4.5kΩ	RESISTOR	RES0402	Generic Resistor	1
R291	275kΩ	RESISTOR	RES0402	Generic Resistor	1
R292	10mΩ/1W	RCWE120610L0JNEA	RES1206C	Current Sense Resistor	1
R4, R5, R8, R9, R12, R13, R16, R17,					

R20, R21, R24, R25, R28, R29, R32, R33, R36, R37, R39, R40, R41, R42, R45, R46	200Ω	RESISTOR	RES0402	Generic Resistor	24
R44, R49, R50, R51, R52, R53, R54, R55, R59, R151, R152, R248, R282	390Ω	RESISTOR	RES0402	Generic Resistor	13
R6, R7, R10, R11, R14, R15, R18, R19, R22, R23, R26, R27, R30, R31, R34, R35, R75, R76, R78, R91, R92, R144, R186, R187, R188	0	RESISTOR	RES0402	Generic Resistor	25
R77, R147, R194, R277	0Ω	No Load	RES0805	Generic Resistor	4
R79, R108, R145, R185	0Ω	No Load	RES0402	Generic Resistor	4
R80, R81, R126, R127, R153, R154, R155, R162, R163, R166, R167, R168, R169	100Ω	RESISTOR	RES0402	Generic Resistor	13

R86, R88, R89, R90, R111, R115, R122, R208	2K	RESISTOR	RES0402	Generic Resistor	8	
R87	25kΩ	RESISTOR	RES0402	Generic Resistor	1	
R93, R109, R156	50Ω	RESISTOR	RES0402	Generic Resistor	3	
R94, R95	49.9kΩ	RESISTOR	RES0402	Generic Resistor	2	
R96, R97, R112, R119, R123, R150, R164, R268	1kΩ	RESISTOR	RES0402	Generic Resistor	8	
SW0, SW1, SW2, SW3, SW4, SW5, SW6, SW7		SWITCH	SW-10SP001	SPDT, Thru Hole, Slide Switch	8	
SW8		SWITCH	MS12ANW03	SPDT, Thru Hole, Slide Switch	1	
X1	25MHz	738B-25-93	FQ5	12 - 40MHz 20pF Crystal Oscillator	1	Fox Electronics

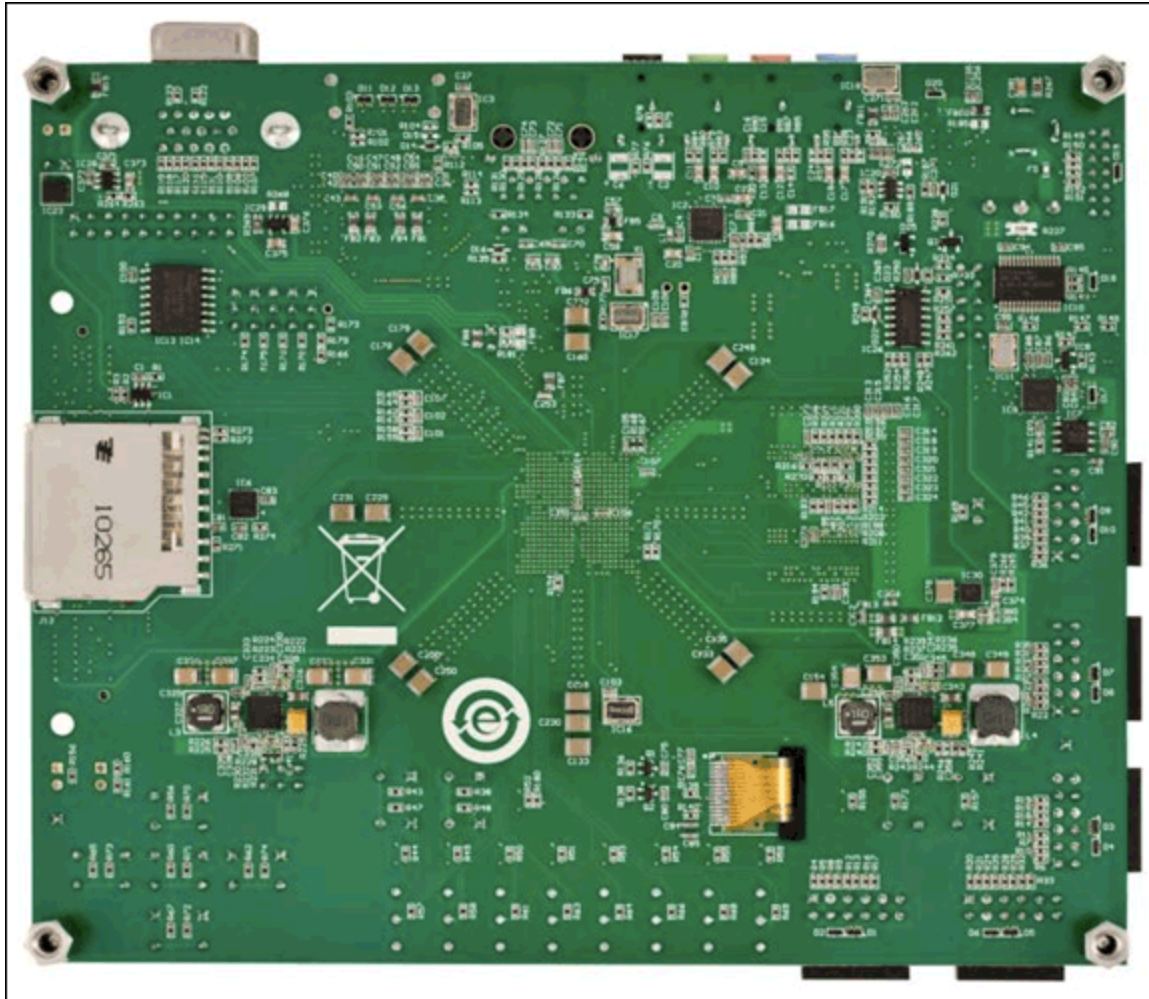

Xilinx is a registered trademark and registered service mark of Xilinx, Inc.
Zynq is a registered trademark of Xilinx, Inc.

Related Parts

MAX15021	Dual, 4A/2A, 4MHz, Step-Down DC-DC Regulator with Tracking/Sequencing Capability	Free Samples
MAX15053	High-Efficiency, 2A, Current-Mode Synchronous, Step-Down Switching Regulator	Free Samples
MAX1510	Low-Voltage DDR Linear Regulators	Free Samples
MAX1983	Low-Voltage, Low-Dropout Linear Regulators with External Bias Supply	Free Samples
MAX6037A	Low-Power, Fixed and Adjustable Reference with Shutdown in SOT23	Free Samples
MAX8686	Single/Multiphase, Step-Down, DC-DC Converter Delivers Up to 25A Per Phase	Free Samples

More Information

For Technical Support: <http://www.maxim-ic.com/support>

For Samples: <http://www.maxim-ic.com/samples>

Other Questions and Comments: <http://www.maxim-ic.com/contact>

Application Note 5449: <http://www.maxim-ic.com/an5449>

REFERENCE DESIGN 5449, AN5449, AN 5449, APP5449, Appnote5449, Appnote 5449

Copyright © by Maxim Integrated Products

Additional Legal Notices: <http://www.maxim-ic.com/legal>